



SHURFLO HIGH FLOW BALLAST

MARINE BALLAST PUMP – PRODUCT TECHNICAL DATA SHEET

OEM: 3300-000
 AFTERMARKET: 3300-001

APPLICATION:

The SHURFLO® High Flow Ballast pump was specially designed and developed for high capacity ballast tank applications in ski and wake boats, providing rapid fill and drain rates in a readily adaptable configuration, able to operate on a 25 Amp circuit. The high efficiency, high torque motor in combination with a high modulus neoprene compound impeller provide fast priming, long life, and consistent performance



PUMP DESIGN:

Type: Reversible Flexible Impeller
 Ports: ½” Internal Pipe Threads, 1” External Hose Barb
 Liquid: 200°F [93°C] Max
 Prime: 4 Feet [1.2 M]
 Run Dry: Not Recommended

ELECTRICAL:

Motor: 12V DC Permanent Magnet, Intermittent Duty
 Protection: Need External Fuse (not supplied)
 Leads (Red): 14.5” [0.36M] Tinned 14 AWG
 Leads (Black): 12.5” [0.31M] Tinned 14 AWG
 Fuse: 25 Amp Recommended
 Control: No Control – External fuse required

MATERIALS OF CONSTRUCTION:

Housings: Bronze
 Impeller: Neoprene
 Hardware: Brass

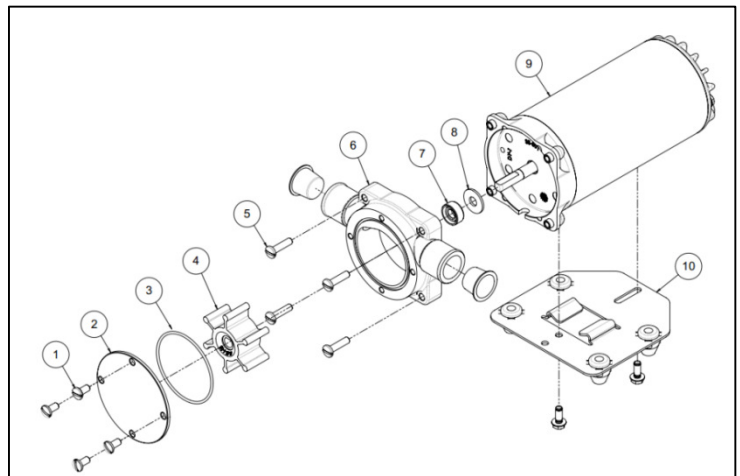

AGENCY APPROVALS:

USCG Electrical Standards 183.410
 ISO 8846 Marine for IGNITION PROTECTION on gasoline power vessels
 CE and IMCI certification

SHIPPING INFORMATION:

Approx. Net Weight: 7 Lbs. [3.2 Kg] each
 Carton Qty.: 6
 Approx. Carton Weight: 50 Lbs. [15 Kg]
 Approx. Carton Size: 24”L X 18”W X 6”H [61cm x 46cm x 15cm]

REPAIR KITS

Item	Description	Part number
1,3,4,5,7,8	Service Kit	94-912-00
4	Impeller Kit	94-916-00
6	Body Kit	94-913-00
1,5	Fasteners Kit	94-914-00
9	Motor Kit	94-71-008-17

RELATED DOCUMENTS:

Catalog: MS-030-140
 Application Spec Guide: MS-020-005
 Installation Manual: 911-1057
 Aftermarket Warranty: 911-1045

TYPICAL PERFORMANCE

PSI	GPM	LPM	AMPS
0	15	56.7	11
5	12.5	47.3	15
10	10	37.8	16
15	7	26.4	17
20	0	0	19

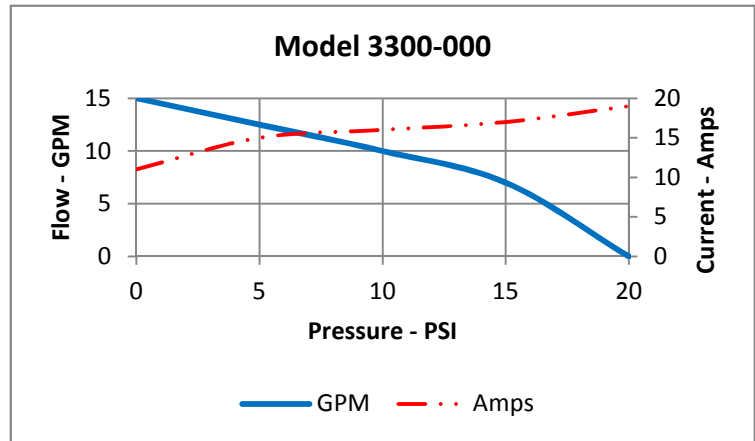

DIMENSIONS

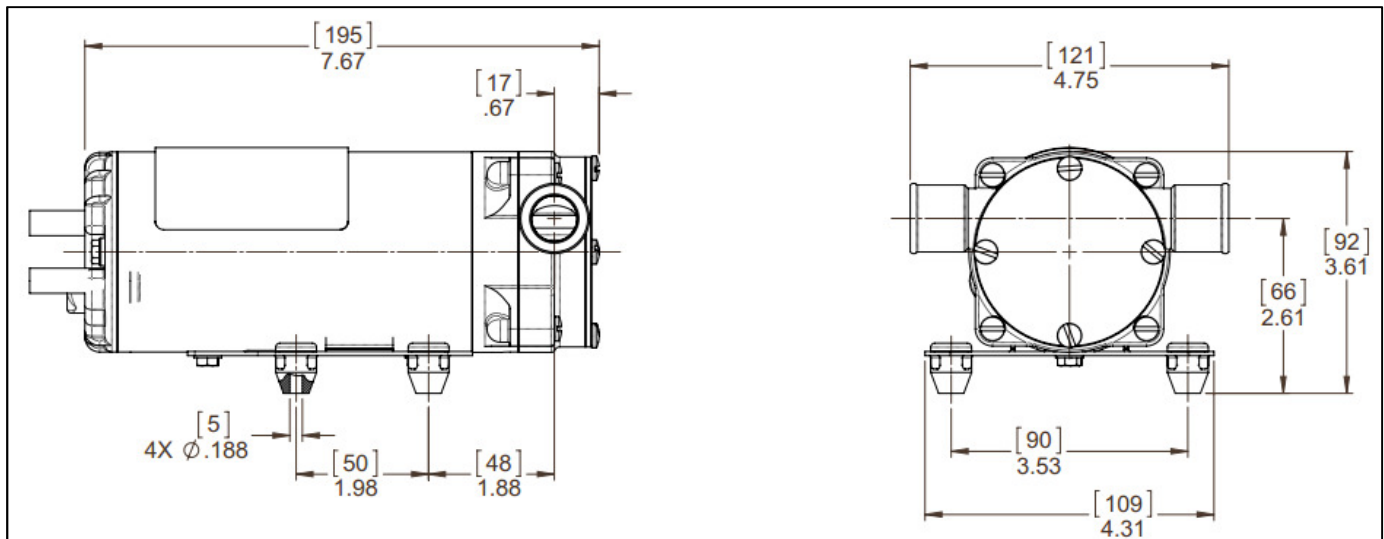

3545 Harbor Gateway South, Suite 103, Costa Mesa, CA 92626, (800) 854-3218 www.SHURFLO.com

All Pentair trademarks and logos are owned by Pentair, Inc. All other brand or product names are trademarks or registered marks of their respective owners. Because we are continuously improving our products and services, Pentair reserves the right to change specifications without prior notice. Pentair is an equal opportunity employer.

3300-000 [01] Rev. 03/17 2016 – 2017 ©Pentair, Inc. All Rights Reserved.